



AG MILLWORKS
HANDCRAFTED DOORS FOR LUXURY OUTDOOR LIVING
SINCE 1986



INSTALLATION GUIDE BI-FOLD PATIO SYSTEMS

LINK TO
INSTALLATION VIDEO



@agmillworks

Tag us in your
installation photos
and videos to be
featured on our
page!



We suggest prefinishing or prepainting doors before installation.

This unit will not operate or lock properly if the frame is not

PERFECTLY PLUMB, LEVEL AND SQUARE.

ENSURE THE JAMB IS INSTALLED 100% PLUMB, LEVEL AND SQUARE USING A LASER LEVEL DEVICE, 6' OR 8' LEVEL AND OR A STORY POLE.

If a factory service call is requested and the cause of the issue is found to be a unit installed out of square and/or plumb, the service call will be billed to the customer.

IMPORTANT:

This unit has been engineered to work with the weatherstripping installed on the unit. If weatherstripping must be removed for painting or finishing, please make note of where it goes before removing it. It is the installer's and or painter's responsibility to replace all weatherstripping in exactly the same locations as installed by factory. Failure to do so may cause the unit to leak water and air.

IMPORTANT: A SILL PAN AND PROPER WATERPROOFING (BY OTHERS) ARE REQUIRED FOR PROPER INSTALLATION OF THIS UNIT FIG 9.

These are not step-by-step instructions. Manufacturer assumes no liability for omissions/errors and/or installation errors. Please call the factory if there are any questions 1-800-559-9995

K.D. Unit (Knocked Down) Assembly
Instructions are written as viewed from EXTERIOR side of unit

Thank you for ordering your Bi-fold Patio Door System from AG Millworks. This unit was completely built-up with all hardware installed in our factory. The unit was fully tested and components were adjusted and then the doors were removed, marked and boxed, and the frame may have been disassembled and boxed. Please contact the factory before making any hardware adjustments.

Please refer to drawings on the following pages for more information.

If the frame was not delivered assembled, assemble and screw together the four sections of the frame: (1) Head Jamb, (2) Jamb legs, (1) Sill using generous amounts of the provided high-quality silicone caulking **FIG 1**. The head jamb will already have the upper pivot set at the edges of the frame and the intermediate carrier set will be free-floating in the upper track on the head jamb. The sill will have the lower pivot set only.

NOTICE: Do not use expanding foam between the frame and the opening. Doing so could bow the frame and result in poor operation and product performance.

Place the frame into the opening and be sure it is **completely plumb, level and square**. Don't forget to apply a minimum of two beads of silicone caulking and/or flashing material to waterproof the unit.

ALUMINUM SILL:

The installer has various options for securing the sill depending on the job site, **e.g. a generous amount of high quality sealant such as OSI Quad Max**. However, be sure all products are compatible with one another. Ultimately, the installer needs to determine the best method to prevent the sill from lifting off the subfloor. Secure the frame into the opening **completely plumb, level and square**. See **FIG 9** for basic sill pan information.

ULTRA GUIDE:

The ultra guide, which is set into a temporary board (**not intended to be used in the installation**), will have the lower pivot set installed in the channel. **Remove the temporary board and proceed with the installation. The board is your TEMPLATE for proper placement of the channel during installation only FIG 2**. The installer has various options for securing the ultra guide depending on the job site, **e.g., a generous amount of high quality sealant such as OSI Quad Max**. However, be sure all products are compatible with one another. Ultimately, the installer needs to determine the best method to prevent the ultra guide from lifting off the subfloor.

Use of temporary shims in the head gap is only for squaring up the frame. Do not screw through shims! Be sure to remove all head jamb shims before finishing the opening. The open gap between the head jamb of the door system and the structural header must be preserved so that if deflection of the structural header develops (as a result of settling, roof loading, etc.) and pushes downward on the head jamb the problem can be remedied. The doors can be folded to one side to take pressure off the head jamb and the head jamb screws can be tightened slightly, pulling the head jamb upward and relieving the deflection of the head jamb and freeing up roller operation. After door panels have been installed, the installer should recheck for head track deflection, as the opening may respond to the weight of the panels.

Be sure the **3" and 4"** header screws don't interfere with the carrier set as it rolls through the channel. **Alternate between the screws and place in a zig zag screw pattern along the head jamb. Screw holes are predrilled for your convenience. Please utilize all predrilled holes for proper support FIG 3.**

FIG 1: Assembling Frame

Assembling Head Jamb to Jamb Leg
(Use generous amounts of high-quality silicone caulking.)

Viewed from Interior



Assembling Aluminum Sill to Jamb Leg
(Use generous amounts of high-quality silicone caulking.)

Viewed from Exterior

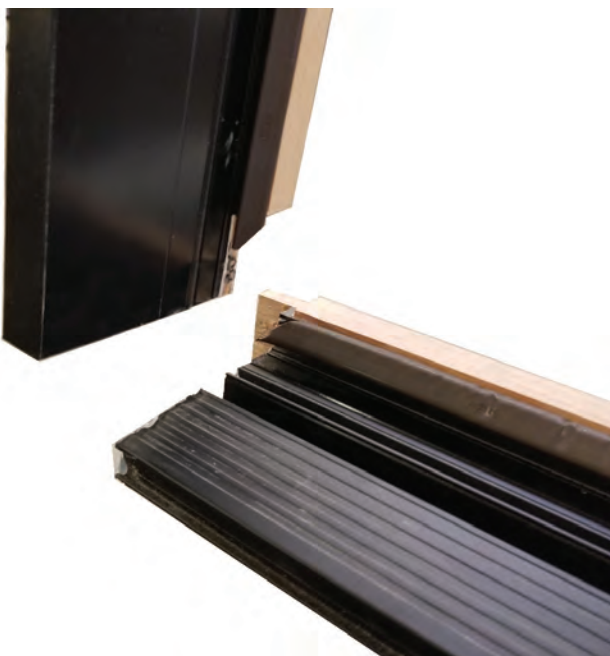
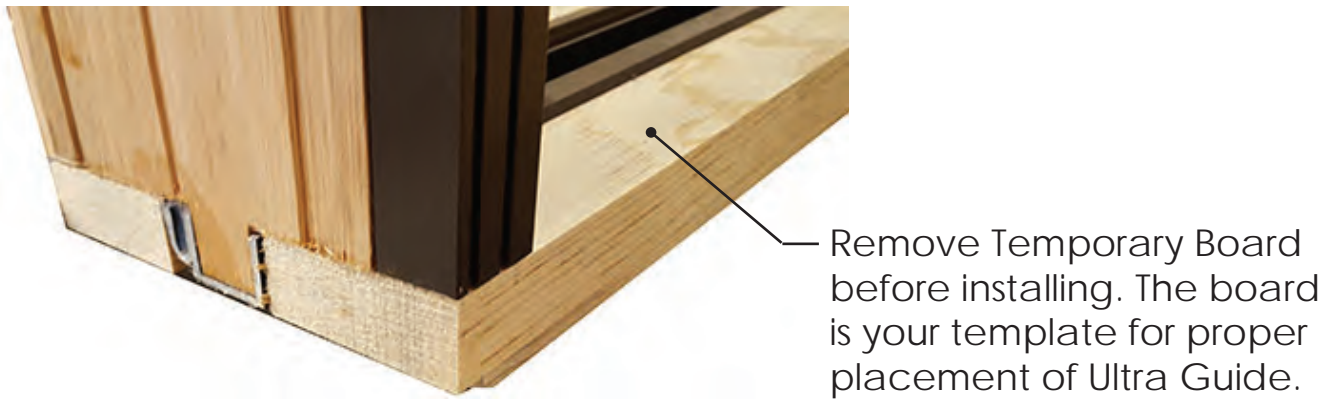

FIG 2: Temporary Board for Ultra Guide. Not intended to be used in the installation.



It is the sole responsibility of the customer to provide an adequate weep system for the ultra guide channel. See FIG 10 for weep system suggestion.

FIG 3: Anchoring the head jamb. Installer should determine if additional screws are required.

Start with 3" screw in channel and alternate between 4" and 3" screws. The screws should be placed closer together (aprx. 3" apart) where the doors will fold together. Otherwise, space screws further apart (aprx. 16").

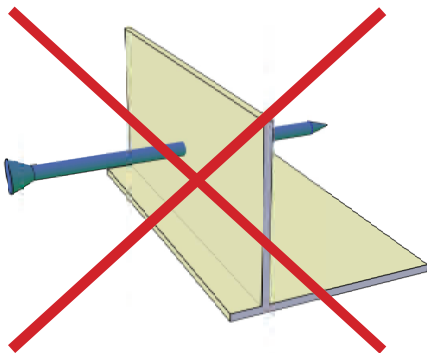
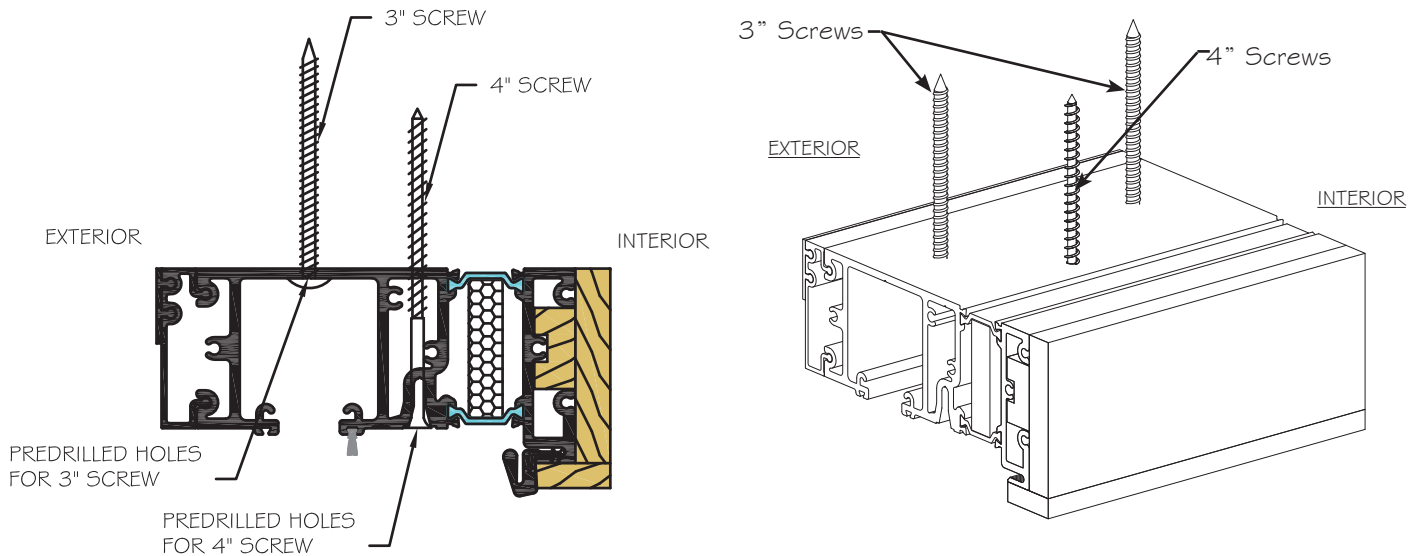

NON-STRUCTURAL FLASHING FIN.

NOT INTENDED TO BE USED AS AN ANCHORING DEVICE OR NAILING FIN.

Secure each vertical jamb leg to the corresponding stud using screws **FIG 4**.

Use the story pole provided to verify the frame is properly installed **FIG 5**.

FIG 4: Securing through leg jamb. Minimum of 3 screws per jamb leg recommended.

Locking Jamb

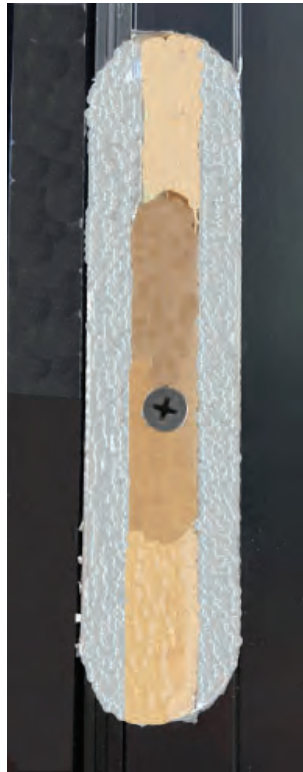

Before applying screws, remove covers to avoid damage.

Exterior



Interior

Reapply covers.

Remove the covers of the top and bottom tongue strikes and the strike plate of the lock to prevent damage. Note the orientation of the covers. Pre-drill screw holes inside the cavities. Apply silicone inside the screw holes. Fasten the jamb to the vertical stud with the stainless steel screws provided. Replace the covers in the proper orientation.

To fasten the hinge jamb, use the provided stainless steel screws along the vertical groove. Pre-drill and countersink screw holes, apply silicone inside the screw hole, and fasten screw. Once the jamb leg is secured use the screw covers to hide the screw caps.

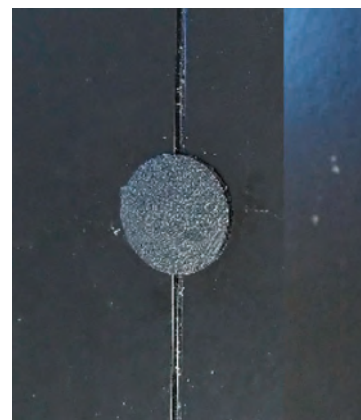
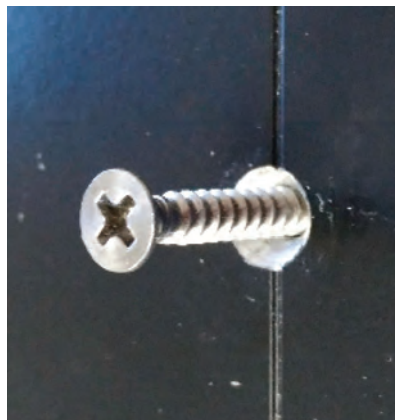
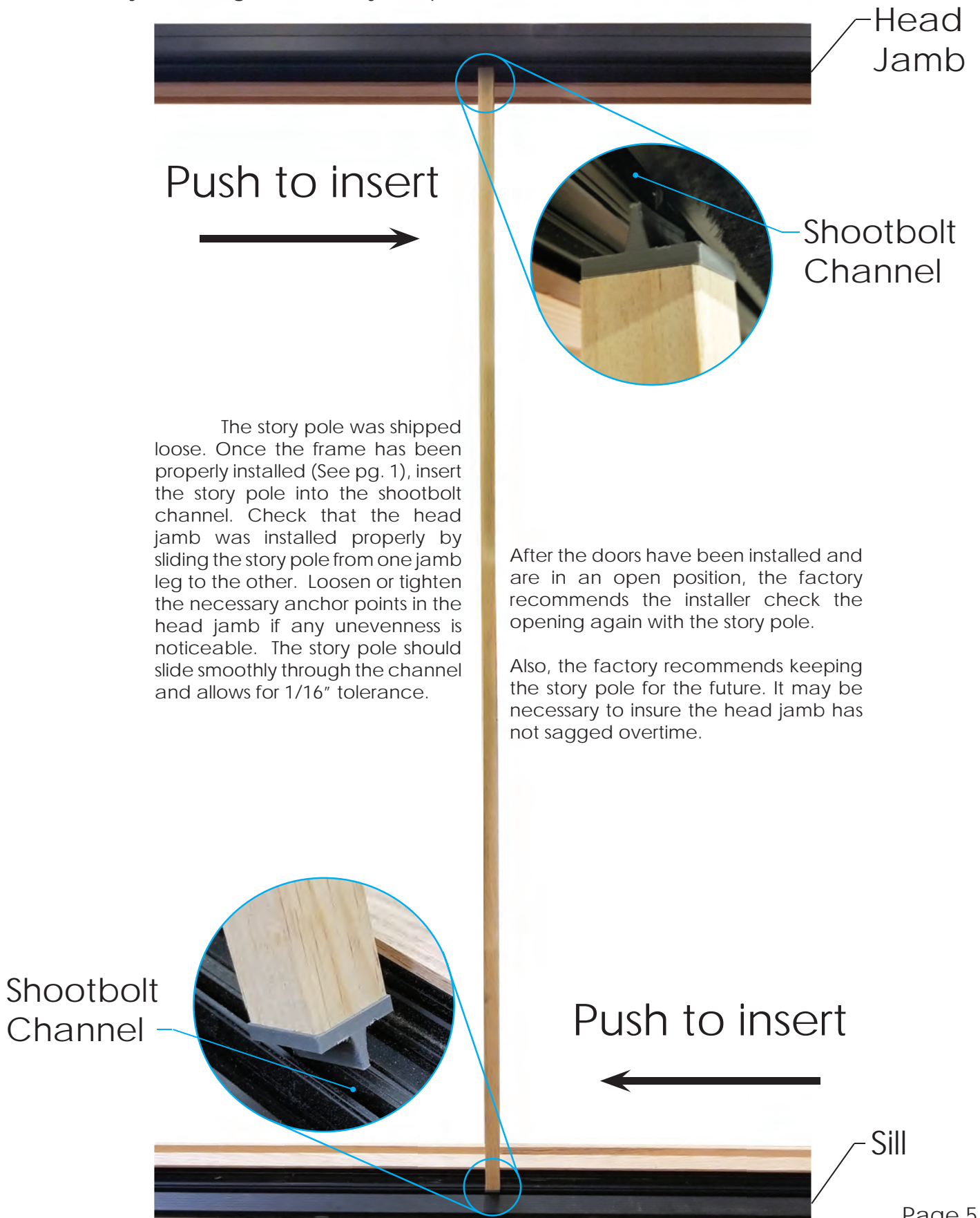

FIG 5: Story Pole

(Story Pole length is cut for your specific unit and allows for 1/16" tolerance.)







The story pole was shipped loose. Once the frame has been properly installed (See pg. 1), insert the story pole into the shootbolt channel. Check that the head jamb was installed properly by sliding the story pole from one jamb leg to the other. Loosen or tighten the necessary anchor points in the head jamb if any unevenness is noticeable. The story pole should slide smoothly through the channel and allows for 1/16" tolerance.

After the doors have been installed and are in an open position, the factory recommends the installer check the opening again with the story pole.







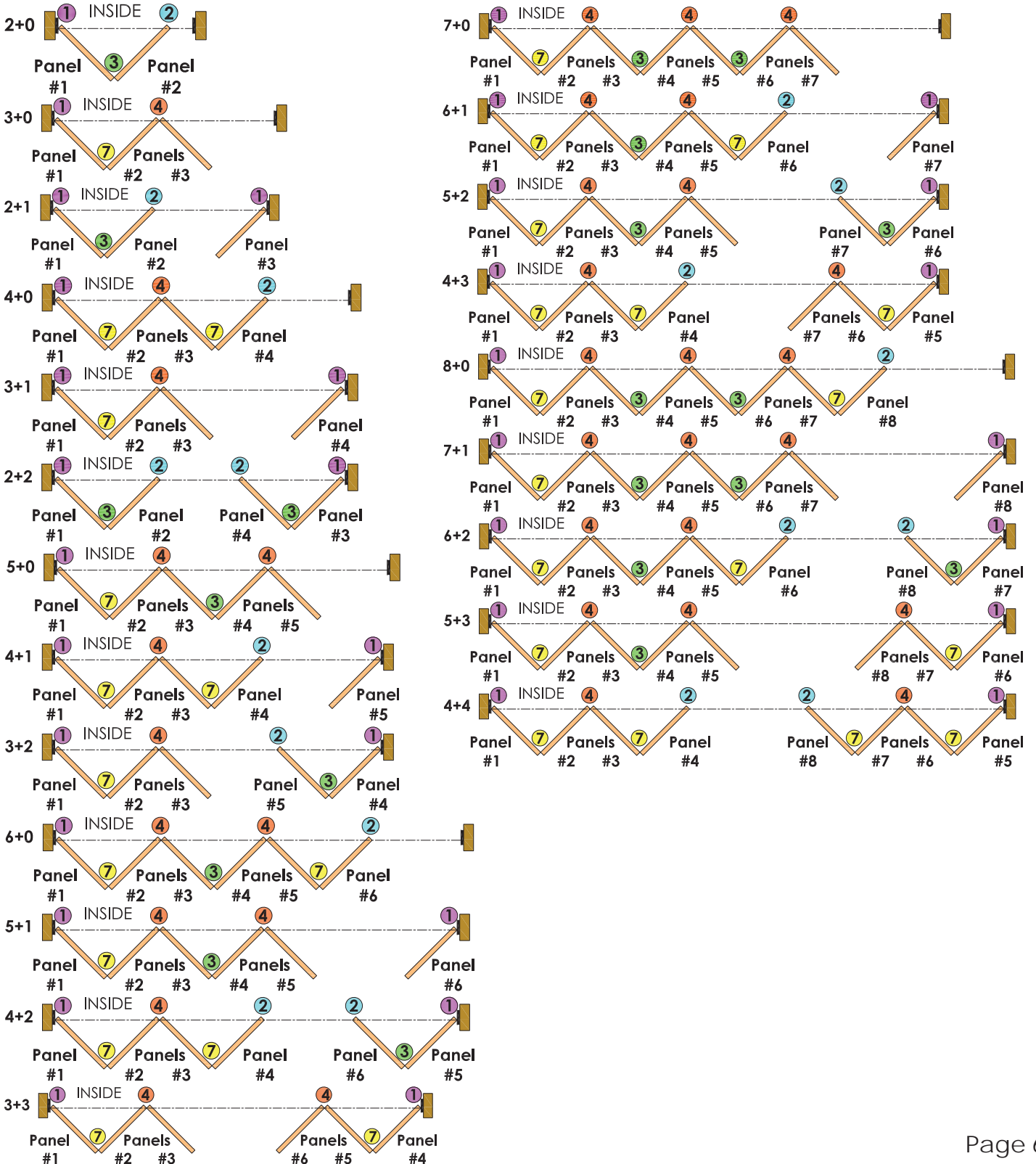

Also, the factory recommends keeping the story pole for the future. It may be necessary to insure the head jamb has not sagged overtime.

Panel Configuration and Hardware Location for Series I

HARDWARE LEGEND		
SYMBOL	REF.	DESCRIPTION
	1	Adjustable pivot set
	2	End hanger set with guide
	3	Hinge set with hinge handle
	4	Intermediate hanger set with guide
	7	Offset hinge set with hinge handle



Panel Configuration and Hardware Location Series II

HARDWARE LEGEND		
SYMBOL	REF.	DESCRIPTION
	1	Adjustable pivot set
	1.B	Jamb Pivot
	2	End hanger set with guide
	3	Hinge set with hinge handle
	4	Intermediate hanger set with guide
	5	Hinge set
	6	Offset hinge set
	7	Offset hinge set with hinge handle

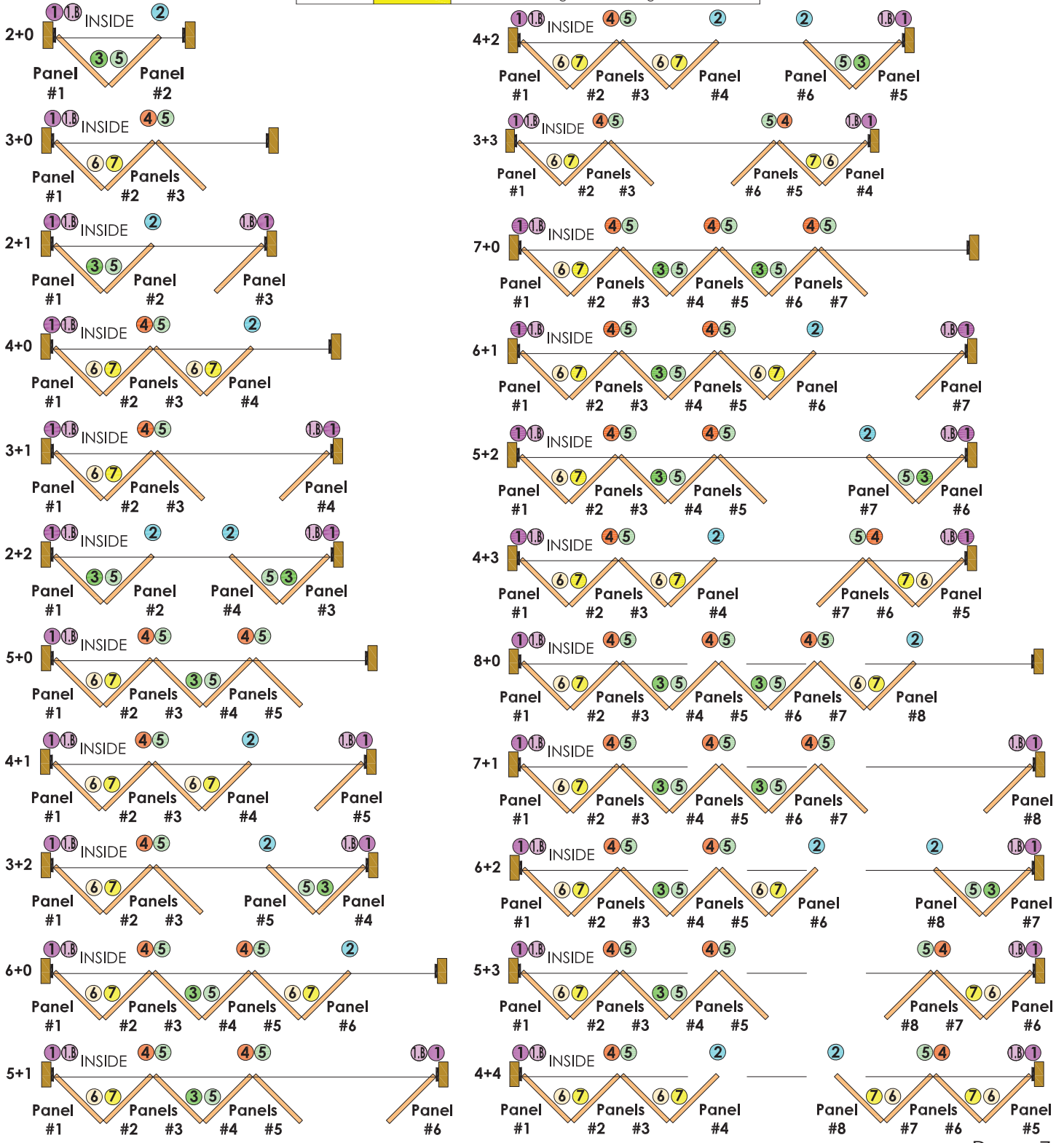

Check again to be sure the jamb is **plumb, level and square** before continuing.

We suggest prefinishing or prepainting panels before installation. This includes accessory kerfs for weatherstripping. Failure to prefinish or prepaint the kerfs could cause water to warp the kerf. This might cause spreading and result in the kerf not holding the weatherstripping any longer.

Panel numbers are marked on the cartons and on the glass of each door. Panels are numbered in the order they are to be installed.

FIG 7: Support bottom of panel.



INSTALLING PANELS

Adjustable Pivot Set: The head jamb and sill will already have the ADJUSTABLE PIVOT SET (1) hardware installed in the frame. Pivot Hinges are located at the jamb legs. The first panel is always attached to the Pivot hinge to anchor the following doors. Angle the panel to the fully open position and support the bottom front edge of panel **FIG 7**. Find the predrilled holes along the back edge of the panel and attach the panel to the top and bottom pivot hinges. For panels over 8'0 tall, there is a jamb pivot hinge (middle hinge) for extra support.

*See appendix A for retractable screen application.

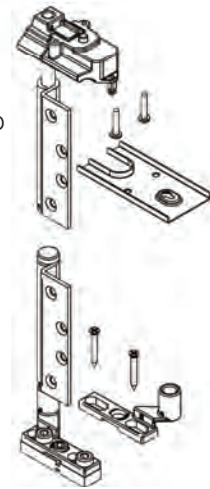

Intermediate Hanger Set with guide: The INTERMEDIATE HANGER SET (4) will be free-floating in the upper track in the head jamb. Guide rollers located on the bottom of panel are protected by wood caps that must be removed. Place the guide rollers into the bottom channel in the fully open position. Support the bottom front edge of panel **FIG 7**. Find the predrilled holes along the leading edge of panel and attach the intermediate hinges. Find the predrilled holes along the back edge of the panel and attach either the Offset Hinge Set with hinge handle (7) or the Hinge Set with hinge handle (3). Either of these will already be attached to the panels.

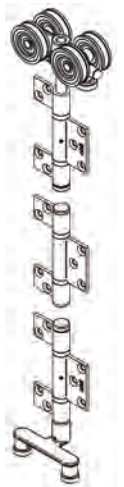

End Hanger Set: If there is an even number of panels going in one direction, the last panel will have an END HANGER SET (2). This end hanger set will be free-floating in the upper track. Place the guide roller on the bottom leading edge of the last panel. Find the predrilled holes and attach End Hanger set in the head jamb to the top leading edge of the last panel.

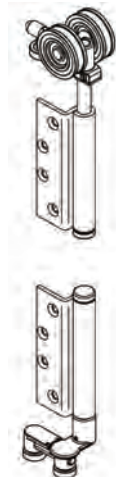

In order to avoid damaging your new doors, be sure to apply a round bumper or the magnetic door holder FIG 8.

8. Test to see if the unit opens and closes smoothly.

FIG 8: Bumper/Door Holder



- Round Bumpers: In order to avoid damaging your doors during folding, apply the round bumper(s) where the handleset will make contact with the aluminum cladding and cause a dent.

- Unscrew the base plate and use screw provided to place. Sandwich bumper between base and top. Screw the top back on to the base plate.

9. Apply handlesets/cylinder thumb-turns if included.

Note: The protruding latch on the edge of the mortise lock is spring loaded and reversible. If the direction is incorrect, firmly grip the top and bottom edges of the latch and pull outward, then rotate the latch 180 degrees to reverse it and release it. Pliers may be necessary.

If there are any questions during installation, please feel free to call our factory at (805) 644-4494 or 1-800-559-9995 (toll free in USA) between the hours of 8:00 a.m. and 4:30 p.m.

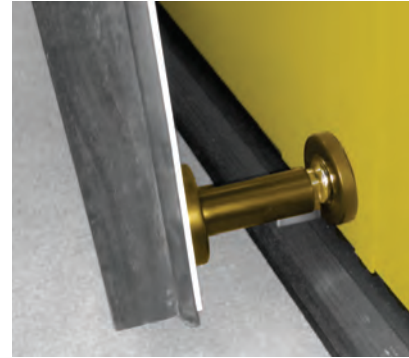

A magnetic door holder has been included in your parts box. This acts as a holder for the manual door and is optional.

Weep Holes must be kept clear of debris to insure proper drainage of sill. Blocked Weep Holes will cause damage to the doors.

Please view are video demonstrating how to keep weep holes clear on our website under Video Gallery.

Extra Weep Hole Covers will be shipped loose in a plastic bag. These should be kept in case replacement of covers is necessary.

Find the prefabricated holes at the front of the sill and firmly insert weep hole cover until it snaps in place.

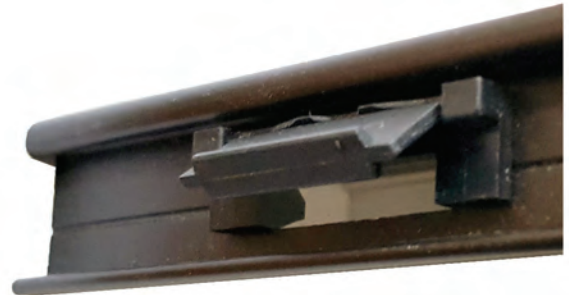

FIG 9: Basic Sill Pan Information-Aluminum Sill Only

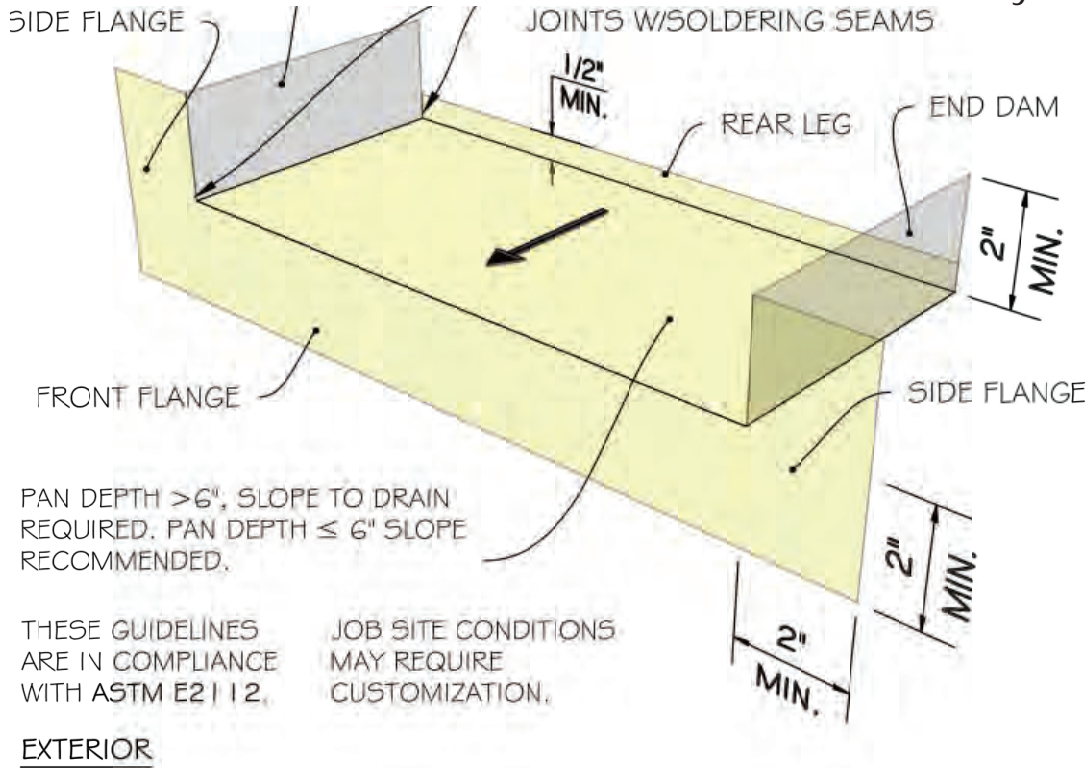
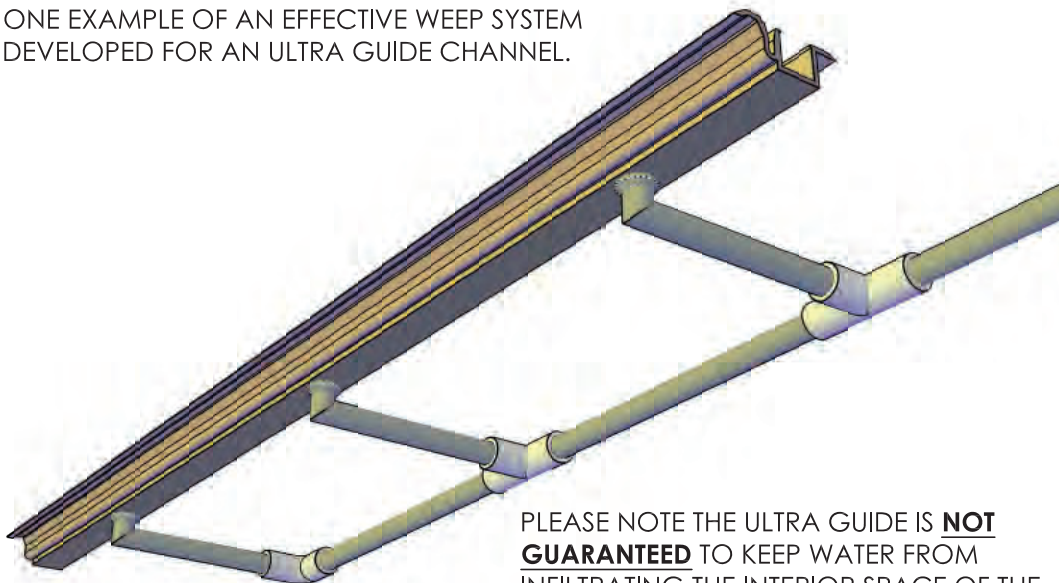

FIG 10: Possible drainage system for Ultra Guide.

Custom site specific drainage can be implemented by installer. Here is one example of an effective weep system developed for an ultra guide channel.

Please note the Ultra Guide channel is not guaranteed to keep water from infiltrating the interior space of the structure. All bi-folds ordered with Ultra Guide have no warranty for water infiltration.

ONE POSSIBLE DRAINAGE SYSTEM FOR ULTRA GUIDE. CUSTOM SITE SPECIFIC DRAINAGE CAN BE IMPLEMENTED BY INSTALLER. HERE IS ONE EXAMPLE OF AN EFFECTIVE WEEP SYSTEM DEVELOPED FOR AN ULTRA GUIDE CHANNEL.



PLEASE NOTE THE ULTRA GUIDE IS **NOT GUARANTEED** TO KEEP WATER FROM INFILTRATING THE INTERIOR SPACE OF THE STRUCTURE. ALL BI-FOLDS ORDERED WITH ULTRA GUIDE HAVE **NO WARRANTY FOR WATER INFILTRATION.**

APPENDIXES

A: RETRACTABLE SCREEN

Because of the proximity of the screen, we recommend the use of an "Offset Bit" to secure the back edge of the first panel to the hinges. Not necessary if screen is pocketed.

Offset Bit (Located in parts box.)

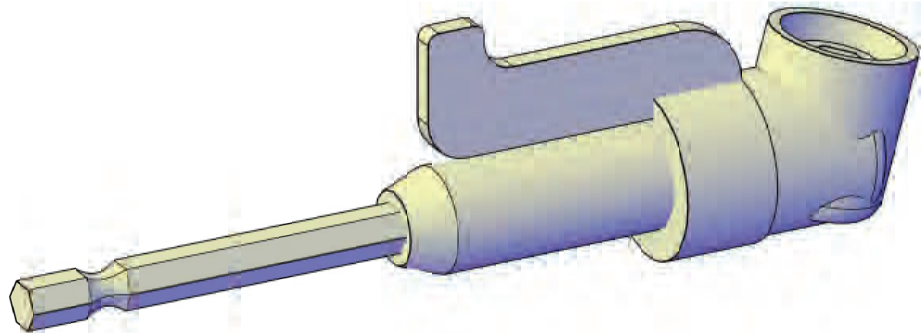

If retractable screen is shipped knocked down, please see installation videos on our website under Video Gallery.

If retractable screen is ordered with an ultra guide channel, the installer must prepare for a screen channel in the finished floor.

EXTERIOR

INTERIOR

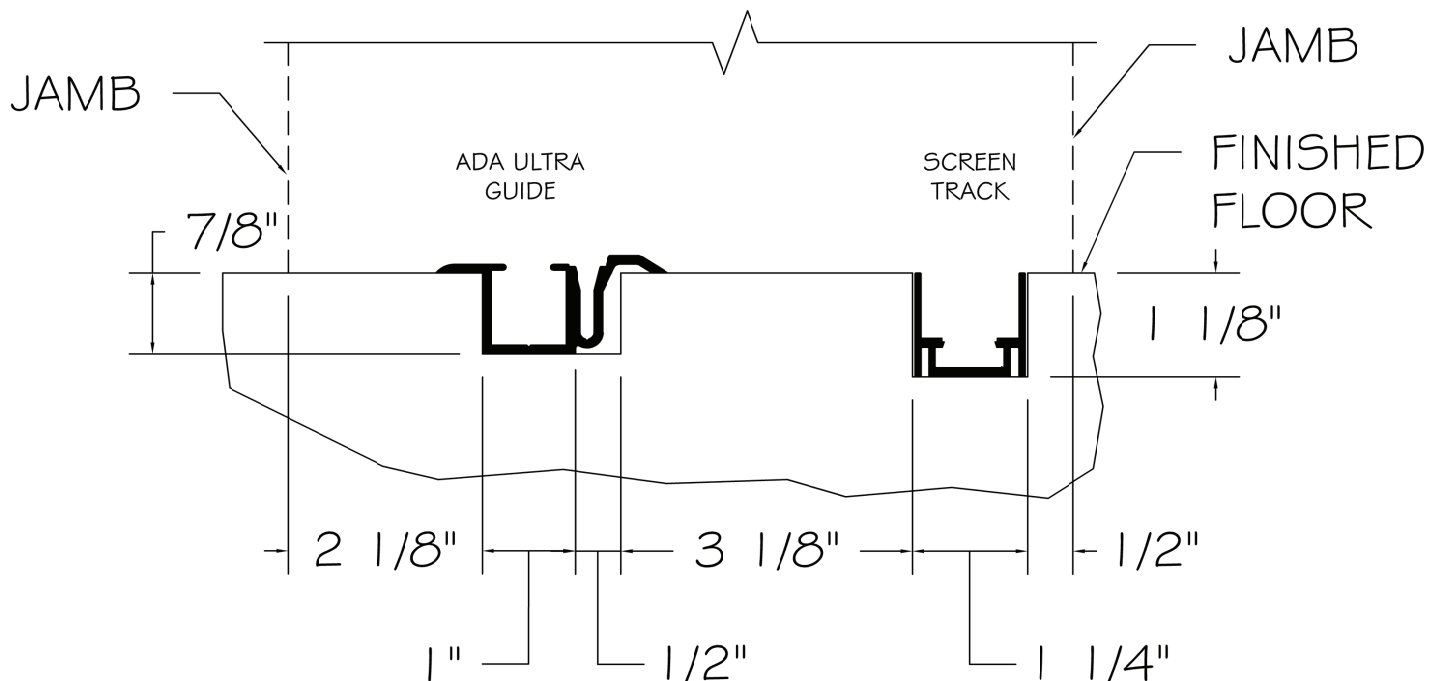

APPENDIXES

B: Adjusting Hinges

Series I - See videos on our website for Series I hinge adjustments under Video Gallery.

Series II



Step 1 Loosen the locking screw by rotating counter-clockwise for 2 turns.

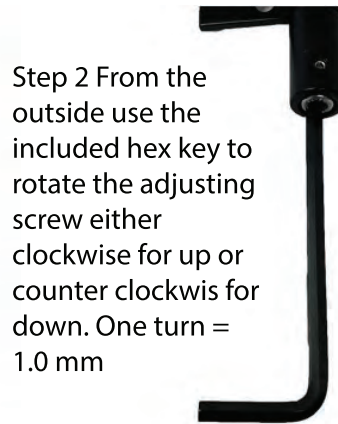

Step 2 From the outside use the included hex key to rotate the adjusting screw either clockwise for up or counter clockwise for down. One turn = 1.0 mm



Step 3 When adjusted open the door system fully and tighten all the security set screws with the included hex key.

C: Pocket Screen Installation

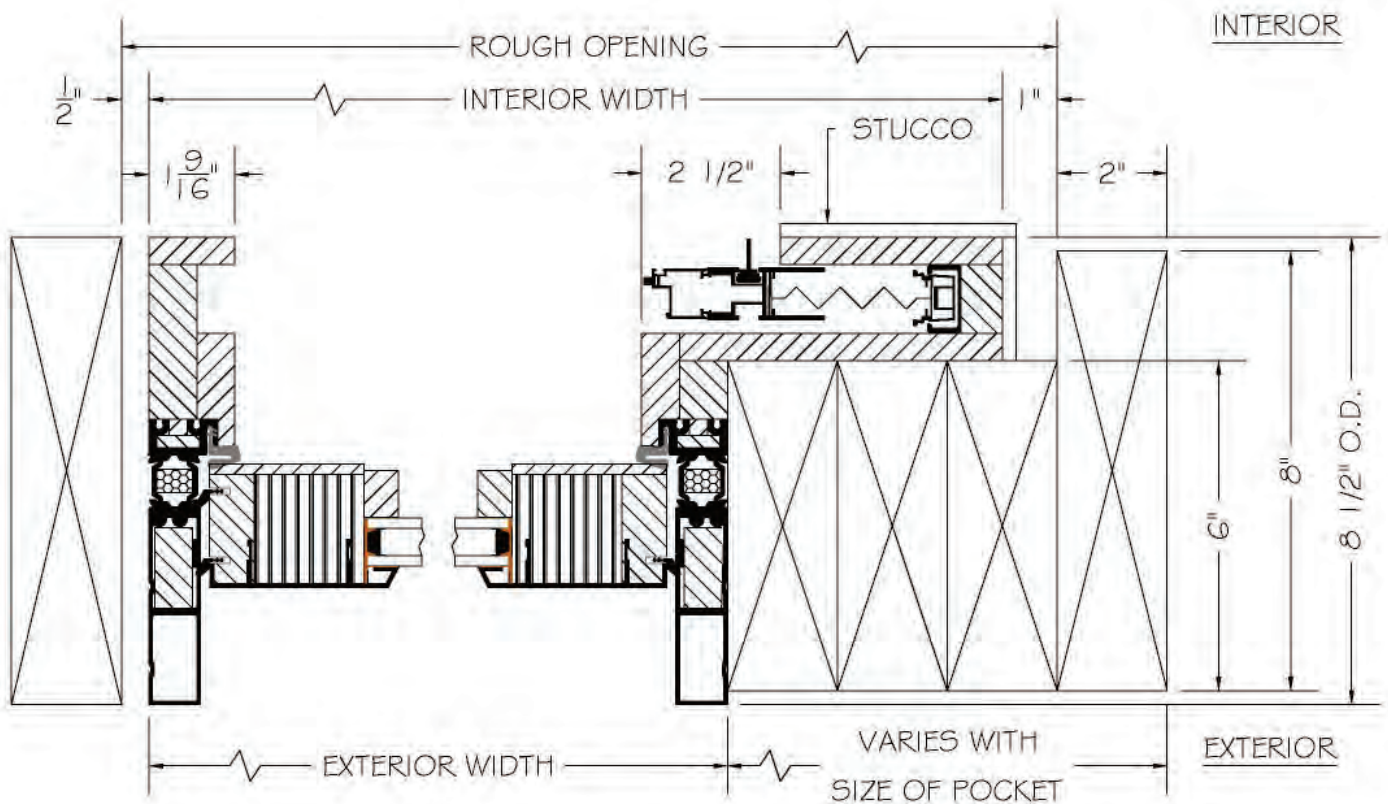

APPENDIXES

D: How to Install 1/2 Shaft

Step 1. Remove the Rubber band

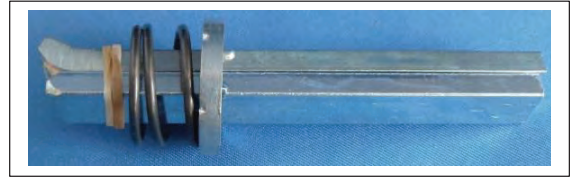

Step 2. Slide the straight 1/2 of the shaft back.

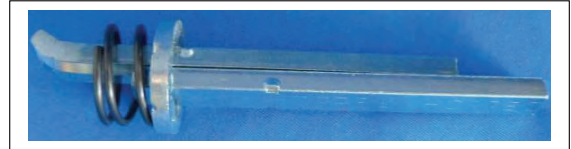

Step 3. Remember to check where your handle Set screw needs to be. To the bottom or to the latch side. Then position the heart shape to that side.

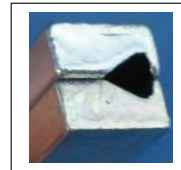

Step 4. Slide the 1/2 of the shaft with the bend through the Hub.



Step 5. Slide the straight spindle into the Hub. It will be tight.



Completed. Time to install the handle sets.

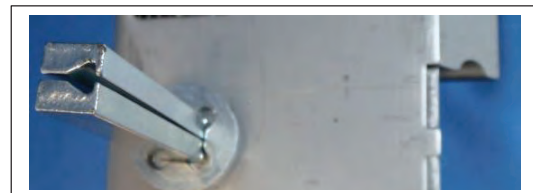

Note: Space is needed on the backside for the spindle to hook on the hub.

